



70L GEAR DRIVE - SHAFT OUTPUT

70,000 in-lb (7,909 N-m) Intermittent Rating 35,000 in-lb (3,954 N-m) Continuous Rating
Typical Applications: Industrial, Marine or Mobile Equipment

(913) 782-1238 (Tel)
(913) 782-4206 (Fax)
Sales@Eskridgeinc.com
www.Eskridgeinc.com
FORM: PS70L A

SHEET 1 OF 8

70L 1-Stage 'A' Base General Dimensions

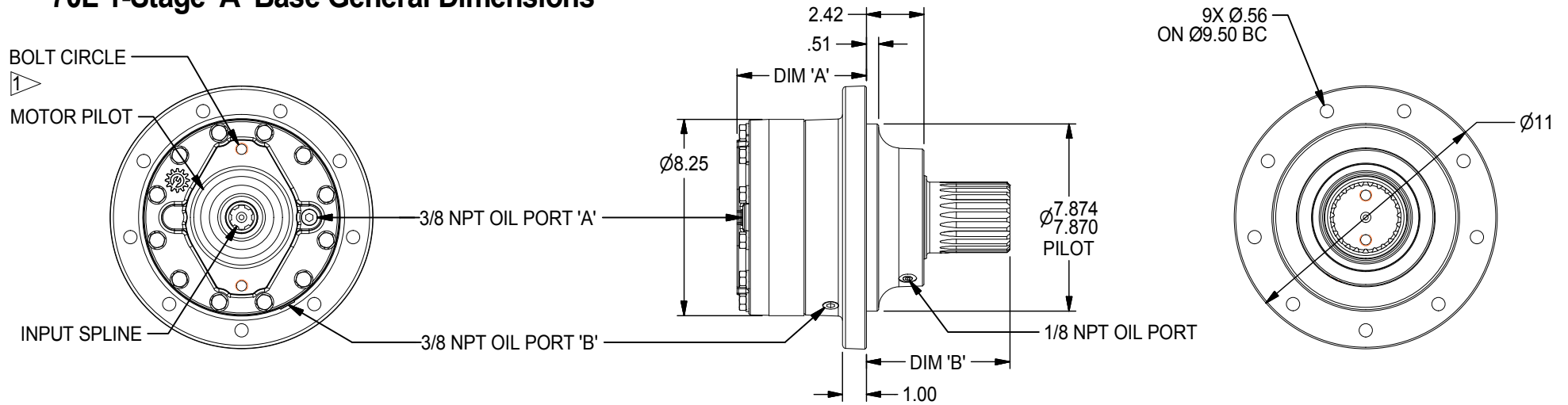

70L 2-Stage 'A' Base General Dimensions

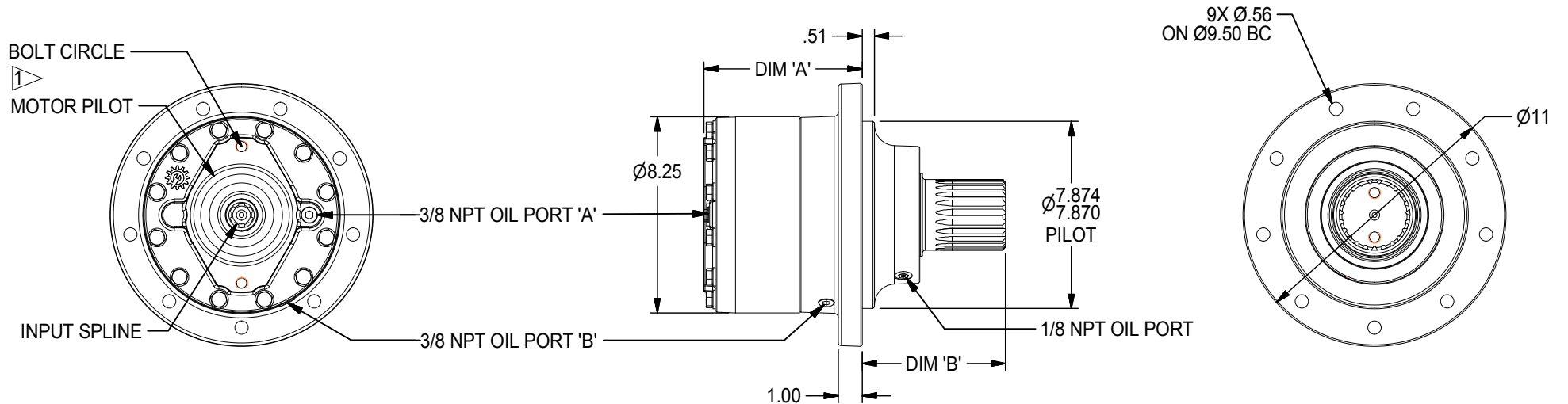



70L GEAR DRIVE - SHAFT OUTPUT

70,000 in-lb (7,909 N-m) Intermittent Rating 35,000 in-lb (3,954 N-m) Continuous Rating
Typical Applications: Industrial, Marine or Mobile Equipment

(913) 782-1238 (Tel)
(913) 782-4206 (Fax)
Sales@Eskridgeinc.com
www.Eskridgeinc.com
FORM: PS70L A

SHEET 2 OF 8

70L 3-Stage 'A' Base General Dimensions

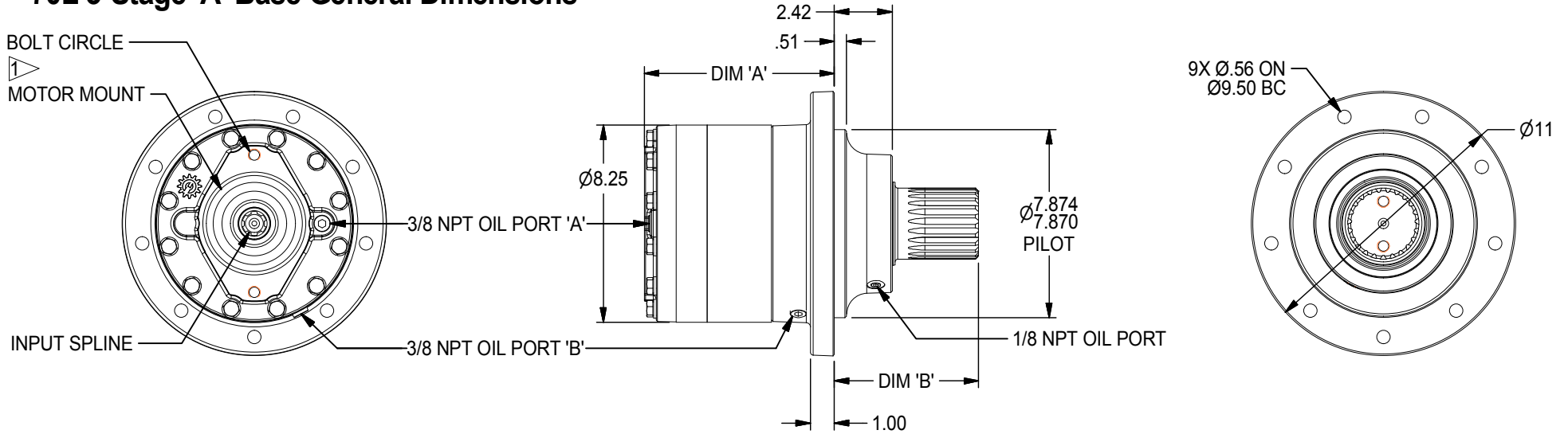

70L 'AQ' Eccentric Base General Dimensions

All other dimensions are identical to Single, 2-Stage & 3-Stage "A" Base

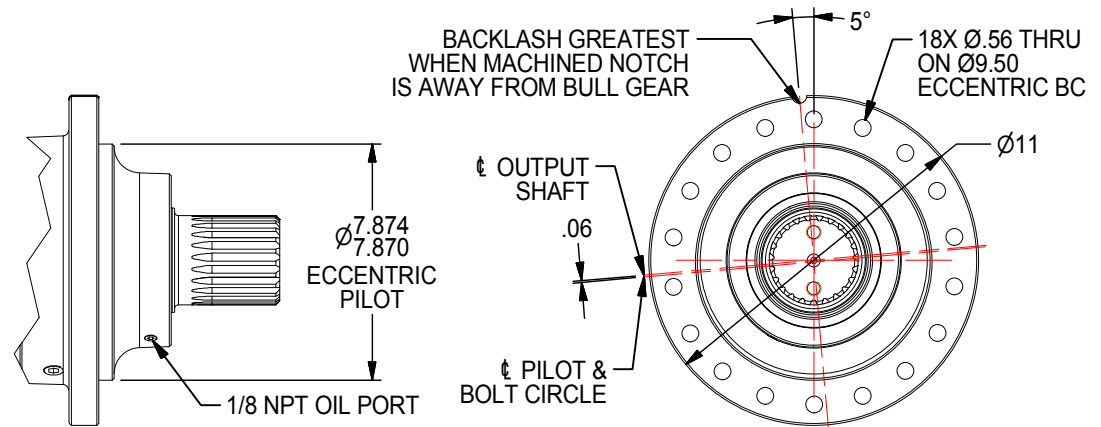



70L GEAR DRIVE - SHAFT OUTPUT

70,000 in-lb (7,909 N-m) Intermittent Rating 35,000 in-lb (3,954 N-m) Continuous Rating
Typical Applications: Industrial, Marine or Mobile Equipment

(913) 782-1238 (Tel)
(913) 782-4206 (Fax)
Sales@Eskridgeinc.com
www.Eskridgeinc.com
FORM: PS70L A

SHEET 3 OF 8

70L 1-Stage 'E' Base General Dimensions

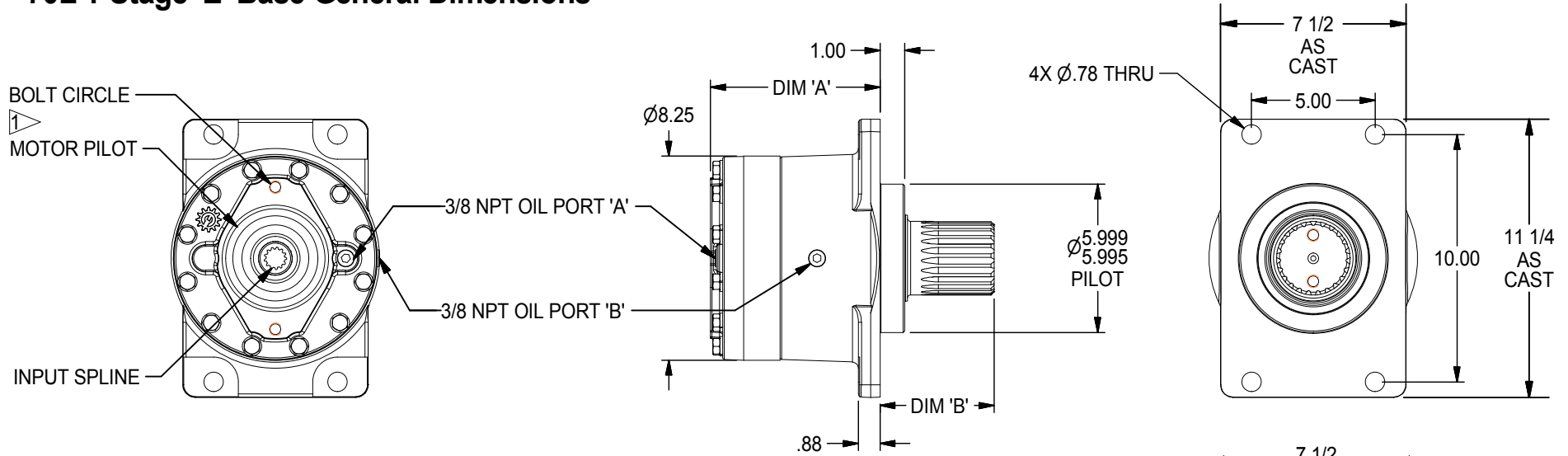

70L 2-Stage 'E' Base General Dimensions

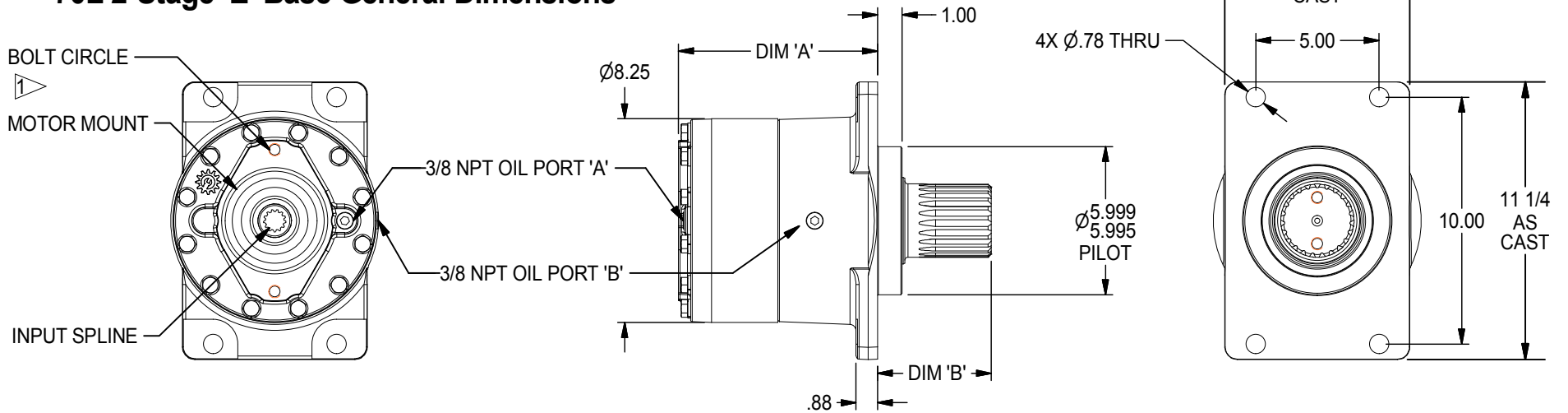



70L GEAR DRIVE - SHAFT OUTPUT

70,000 in-lb (7,909 N-m) Intermittent Rating 35,000 in-lb (3,954 N-m) Continuous Rating
Typical Applications: Industrial, Marine or Mobile Equipment

(913) 782-1238 (Tel)
(913) 782-4206 (Fax)
Sales@Eskridgeinc.com
www.Eskridgeinc.com
FORM: PS70L A

SHEET 4 OF 8

70L 3-Stage 'E' Base General Dimensions

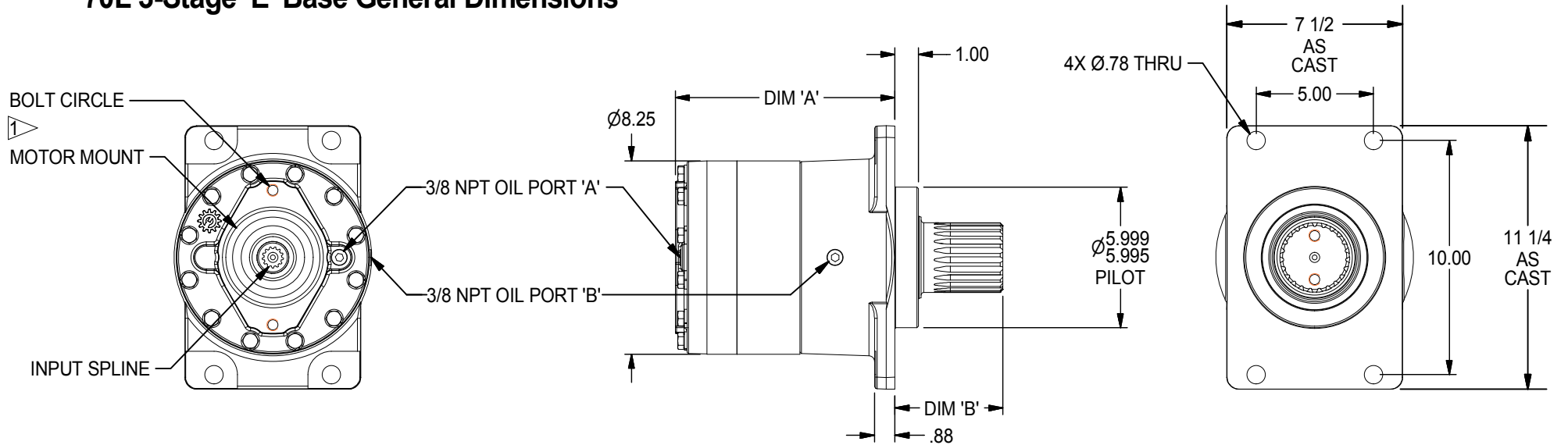



70L GEAR DRIVE - SHAFT OUTPUT

70,000 in-lb (7,909 N-m) Intermittent Rating 35,000 in-lb (3,954 N-m) Continuous Rating
 Typical Applications: Industrial, Marine or Mobile Equipment

(913) 782-1238 (Tel)
 (913) 782-4206 (Fax)
Sales@Eskridgeinc.com
www.Eskridgeinc.com
 FORM: PS70L A

SHEET 5 OF 8

Output Shaft Options Values are shown as inches.

D1 Output Shaft
 23T 8/16 DP Spline

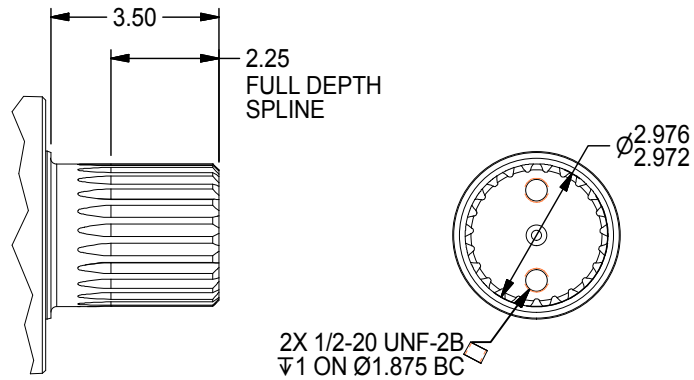

D2 Output Shaft
 $\phi 3.00$ X 5/8" Keyway

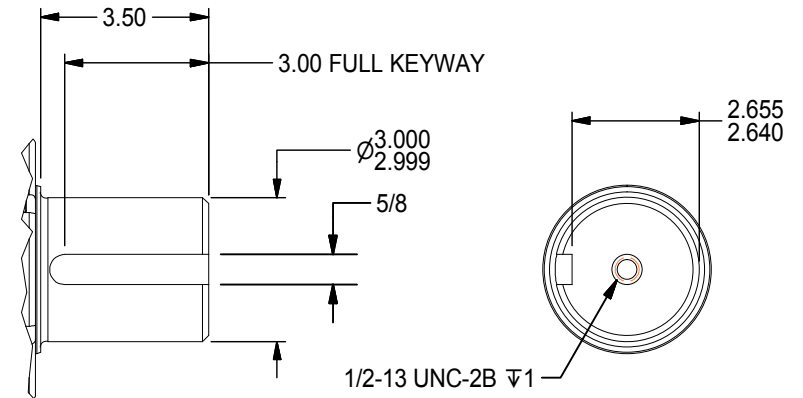

D3 Output Shaft
 $\phi 2 \frac{1}{4}$ x 1/2 Keyway

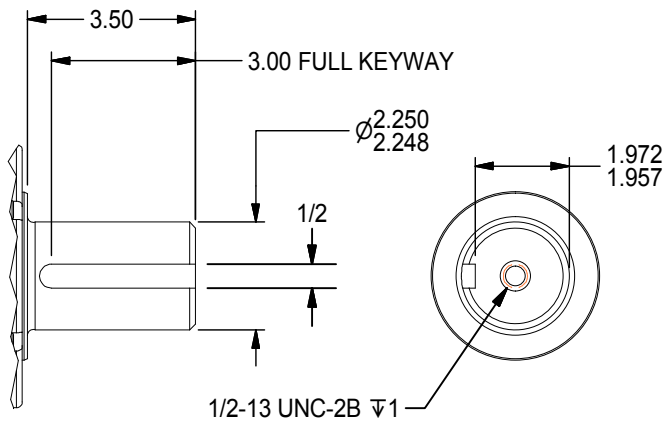

H2 Output Shaft
 2" Hex

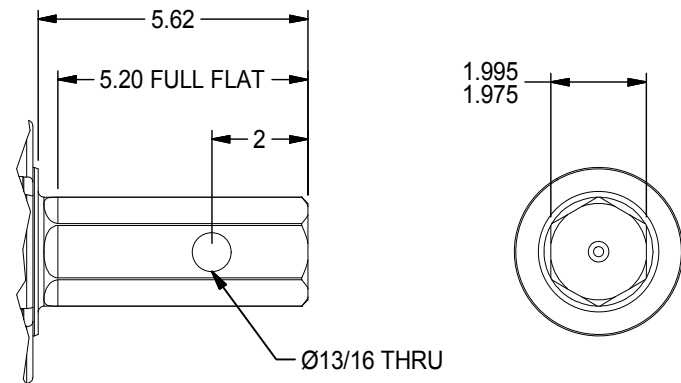



70L GEAR DRIVE - SHAFT OUTPUT

70,000 in-lb (7,909 N-m) Intermittent Rating 35,000 in-lb (3,954 N-m) Continuous Rating
 Typical Applications: Industrial, Marine or Mobile Equipment

(913) 782-1238 (Tel)
 (913) 782-4206 (Fax)
 Sales@Eskridgeinc.com
 www.Eskridgeinc.com
 FORM: PS70L A

SHEET 6 OF 8

Performance Ratings

Maximum Intermittent Output Torque: 70,000 in-lb (7,909 N-m)
 Continuous Output Torque: 35,000 in-lb (3,954 N-m)
 Maximum Input Speed: 3,000 RPM
 Maximum Operating Ambient Temperature: 110° F (43° C)
 Minimum Operating Ambient Temperature: -20° F (-28° C)

Above ratings are general mechanical ratings, not thermal ratings. Continuous duty may require additional cooling. Consult your Eskridge representative to determine ratings for your specific application or configuration

Oil Capacities

Mounting Position	Single Stage	Two Stage	Three Stage
Vertical Shaft Up	1.75 PT Fill to Port 'B'	2.75 PT Fill to Port 'B'	3.25 PT FILL to Port 'B'
Vertical Shaft Down	1.75 PT Fill to 1.5" from Port 'A'	2.75 PT Fill to 1.5" from Port 'A'	3.25 PT Fill to 1.5" from Port 'A'
Horizontal Shaft	1.25 PT Fill to Port 'A'	1.50 PT Fill to Port 'A'	1.75 PT Fill to Port 'A'

ALL UNITS SHIPPED WITHOUT OIL
 Use EP or API GL-5 Designated Lubricants

Motor Mount Dimensions

PILOT DIMENSIONS	BOLT CIRCLE
*SAE 'A' Ø3.251/3.253	4X 1/2-13 UNC-2B √5/8 ON Ø4.188 B.C.
*SAE 'B' Ø4.001/4.005	2X 1/2-13 UNC-2B √.50 ON Ø5.750 B.C.
SAE 'C' Ø5.001/5.004	4X 1/2-13 UNC-2B √1 ON Ø6.375 B.C. 2X 5/8-11 UNC-2B √1 ON Ø7.125 B.C.

Approximate Unit Weights (lbs)

Gear Drive Mounting	Stages		
	Single	Double	Triple
A & AQ	90	105	120
E	90	105	115

Dimension 'A' Specifications

Gear Drive Mounting	Input Mounting, Option A SAE A - 2 & Modified 4 Bolt			Input Mounting, Option B SAE B - 2 Bolt			Input Mounting, Option C SAE C - 4 Bolt			Input Mounting, Option K SAE C - 2 Bolt		
	Single Planetary	Double Planetary	Triple Planetary	Single Planetary	Double Planetary	Triple Planetary	Single Planetary	Double Planetary	Triple Planetary	Single Planetary	Double Planetary	Triple Planetary
A	5.44	6.66	7.95	5.44	6.66	7.95	5.79	7.01	8.30	5.79	7.01	8.30
AQ	5.44	6.66	7.95	5.44	6.66	7.95	5.79	7.01	8.30	5.79	7.01	8.30
E	6.31	7.53	8.82	6.31	7.53	8.82	6.66	7.88	9.17	6.66	7.88	9.17

Dimension 'B' Specifications

Gear Drive Mounting	SHAFT OPTIONS			
	D1	D2	D3	H2
A	6.03	6.03	6.03	8.15
AQ	6.03	6.03	6.03	8.15
E	4.61	4.61	4.61	6.73

NOTES: ▷

- SPECIFICATION CALLED OUT IN MOTOR MOUNT DIMENSIONS SECTION.
- VALUES ARE SHOWN IN INCHES.
- OUTPUT SHAFT ROTATION SAME AS INPUT ROTATION.



70L GEAR DRIVE - SHAFT OUTPUT

70,000 in-lb (7,909 N-m) Intermittent Rating 35,000 in-lb (3,954 N-m) Continuous Rating
 Typical Applications: Industrial, Marine or Mobile Equipment

(913) 782-1238 (Tel)
 (913) 782-4206 (Fax)
Sales@Eskridgeinc.com
www.Eskridgeinc.com
 FORM: PS70L A

SHEET 7 OF 8

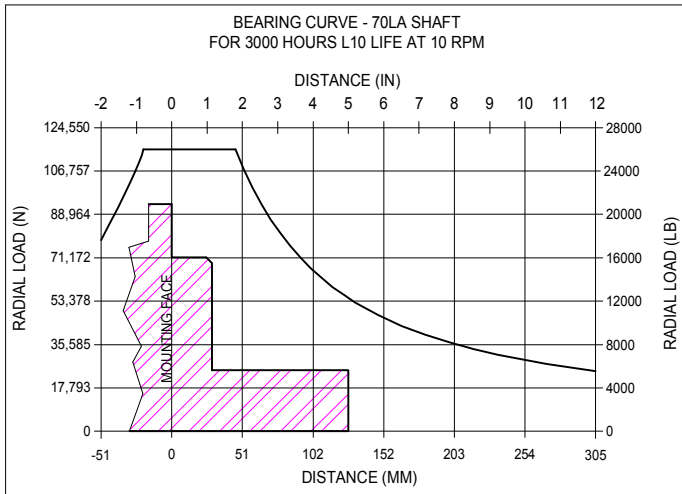

To adjust for loads and speeds other than those shown on above curve, use this formula:

$$\text{Adjusted Life (hours)} = 3000 \left(\frac{10 \text{ rpm}}{\text{Speed (Adjusted)}} \right) \times \left(\frac{\text{Load (Curve)}}{\text{Load (Adjusted)}} \right)^{10/3}$$

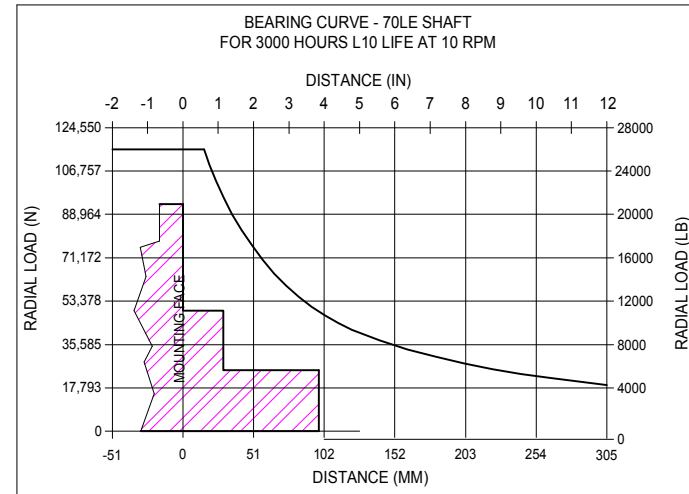

To adjust for loads and speeds other than those shown on above curve, use this formula:

$$\text{Adjusted Life (hours)} = 3000 \left(\frac{10 \text{ rpm}}{\text{Speed (Adjusted)}} \right) \times \left(\frac{\text{Load (Curve)}}{\text{Load (Adjusted)}} \right)^{10/3}$$



70L GEAR DRIVE - SHAFT OUTPUT

70,000 in-lb (7,909 N-m) Intermittent Rating 35,000 in-lb (3,954 N-m) Continuous Rating
 Typical Applications: Industrial, Marine or Mobile Equipment

(913) 782-1238 (Tel)
 (913) 782-4206 (Fax)
Sales@Eskridgeinc.com
www.Eskridgeinc.com
 FORM: PS70L A

SHEET 8 OF 8

Ordering Information

Example Part Number: 70LAD1A2-14-Z

